

# XF1R2® SPECIFICATIONS



## XF One Piece Solutions



Shown with document holder



Shown with optional FAP 30 reader

### Integrated Thermal Printer:

- Printing Method: Direct Thermal
- Resolution: 203 dots/inch
- Media Width: 3.125 in. (80mm) max.
- Print Width: 2.8 inches (72mm)
- Control: SDK
- Sensors: Paper Out/Black Mark, Cover Open
- Retracting stainless steel cutting blade
- Paper Type: Direct thermal roll/variable length printing on polyvinyl

### Power:

- Input: 15VDC @ 3A

### Supplemental Battery:

- Type: Lithium-Ion
  - Capacity: 2900 mAh (7.4V) MIL-STD-810
  - Charge Temperature: +5° to +45° C\*
  - Operating Temperature: -20° to +60° C\*
- \*Actual temperature of battery (not ambient)

### Charging:

- XF Dock
- XF Car Charger via XF Charging Cable
- XF PD Power Supply via XF Charging Cable

### Connectivity:

- USB: Micro USB 3.0 Type C

### LED Indicators:

- Charging State
- Battery Status
- Used Defined (requires SDK)

### Function Key:

- Form Feed and/or Used Defined Function key (requires SDK)

### Options

- High Performance 1D/2D Barcode Scanner
- HID® NOMAD™ FAP30 Fingerprint Reader

### Warranties:

- One Year for manufacturing defects
- Optional extended warranty plans available (up to five years)

### Certifications & Approvals:

- FCC Part 15 Subpart B
- Innovation, Science and Economic Development Canada ICES-003, Issue 7

### Accessories:

- USB-C PD Wall Charger
- Charging Cable
- Spare "Hot Swap" Supplemental Battery
- Car Charger
- Carrying Handle
- Carrying Case
- Shoulder Strap
- Hand Strap
- Single Position Charging Dock
- Four Position Charging Dock

### Dimensions:

#### XF with Samsung S22 Ultra:

#### Weight:

Samsung S22 Ultra:	8.04 oz.
XF POD for S22 Ultra:	8.74 oz.
Integrated Printer:	11.23 oz.
Hand Strap:	0.15 oz.
Battery:	3.82 oz.
<u>Full Paper Roll:</u>	<u>2.52 oz.</u>
<b>Total:</b>	<b>34.50 oz.</b>

Add 2.86 oz. for optional barcode reader

Height: 11.154"

Width: 4.838"

Depth: 2.957"

#### XF with Samsung Note20:

#### Weight:

Samsung Note20:	6.76 oz.
XF POD for Note20:	8.09 oz.
Integrated Printer:	11.23 oz.
Hand Strap:	0.15 oz.
Battery:	3.82 oz.
<u>Full Paper Roll:</u>	<u>2.52 oz.</u>
<b>Total</b>	<b>32.57 oz.</b>

Add 2.86 oz. for optional barcode reader

Height: 10.790"

Width: 4.838"

Depth: 2.957"

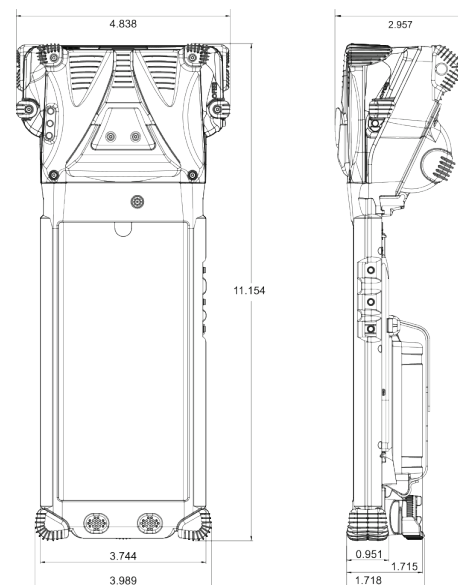

XF with Samsung S22 Ultra

# XF1R2® SPECIFICATIONS



## XF Printer



### Printer:

- Printing Method: Direct Thermal
- Resolution: 203 dots/inch
- Media Width: 3.125 in. (80mm) max.
- Print Width: 2.8 inches (72mm)
- Control: SDK
- Sensors: Paper Out/Black Mark, Cover Open
- Retracting stainless steel cutting blade allows use of polyvinyl media
- Paper Type: Direct thermal roll/variable length printing on polyvinyl
- Connectivity: Bluetooth®, Version 5.0, Class 2, BLE

### Printer Battery:

- Type: Lithium-Ion
  - Capacity: 2900 mAh (7.4V)
  - Charge Temperature: +5°C to +45° C\*
  - Operating Temperature: -20°C to +60° C\*
- \*Actual temperature of battery (not ambient)

### Charging:

- XF Dock
- XF Car Charger via XF Charging Cable
- XF PD Power Supply via XF Charging Cable

### LED Indicators:

- Charging State
- Battery Status
- Used Defined (requires XF SDK)

### Function Key:

- Form Feed and/or Used Defined Function key (requires XF SDK)

### OS Compatibility:

- Android 12 and 13

### Options:

- High Performance 1D/2D Barcode Scanner

### Warranties:

- One Year for manufacturing defects
- Optional extended warranty plans available (up to five years)

### Certifications & Approvals:

- FCC Part 15 Subpart B
- Innovation, Science and Economic Development Canada ICES-003, Issue 7

### Accessories:

- USB-C PD Wall Charger
- Single Position Charging Dock
- Charging Cable
- Four Position Charging Dock
- Car Charger
- Printer Pedestal for Charging Dock
- Spare Printer Battery

### Dimensions:

#### Weight:

Printer:	14.39 oz.	Height:	4.040"
Belt Clip:	0.45 oz.	Height w/Belt Clip:	7.402"
Battery:	3.82 oz.	Width:	4.868"
Full Paper Roll:	2.52 oz.	Depth:	3.854"
Rain Guard:	0.96 oz.		
<b>Total:</b>	<b>22.14 oz.</b>		

Add 2.86 oz. for optional barcode reader

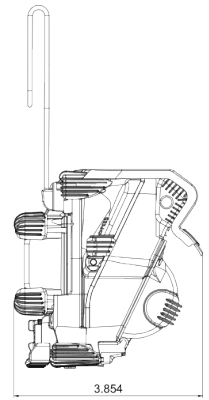
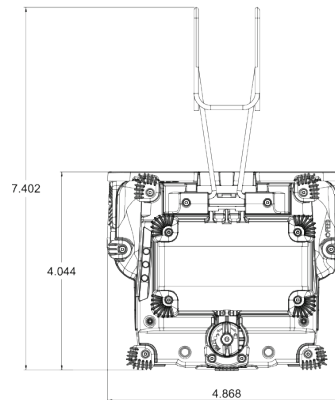

419 Sargon Way, Horsham, PA 19044  
Office: 215.441.5305 • Sales: 215.773.7193  
[www.2T.com/spc1.html](http://www.2T.com/spc1.html)



Copyright © 2023 Two Technologies, Inc. All rights reserved. Two Technologies, Inc., 2T, XF1R2, and the Two Technologies logo are registered trademarks of Two Technologies, Inc. Android is a trademark of Google LLC. Other products or company names mentioned herein may be the trademarks or registered trademarks of their respective companies.

FRM0662, Rev A. 041123